

Packaging Information / Reference Pattern Layout Dimensions

● SSOT-24

Unit: mm

■ Packaging Information

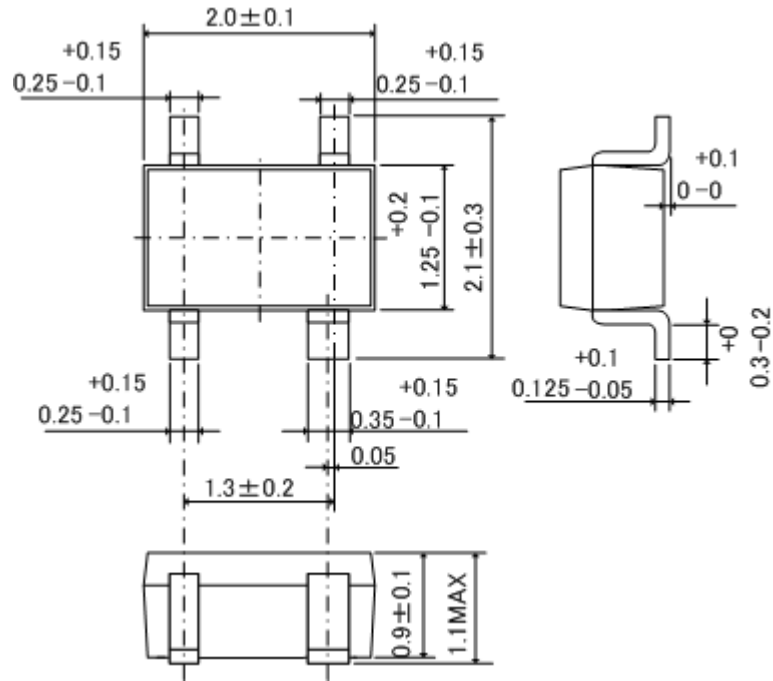

■ Reference Pattern Layout Dimension

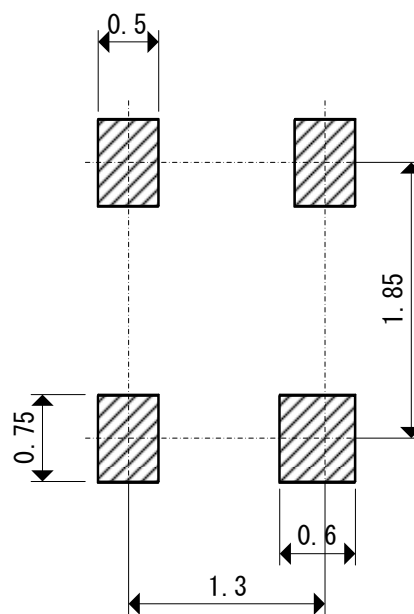

テーピング仕様 / Taping Specifications

SSOT-24

Unit: mm

●リール/Reel

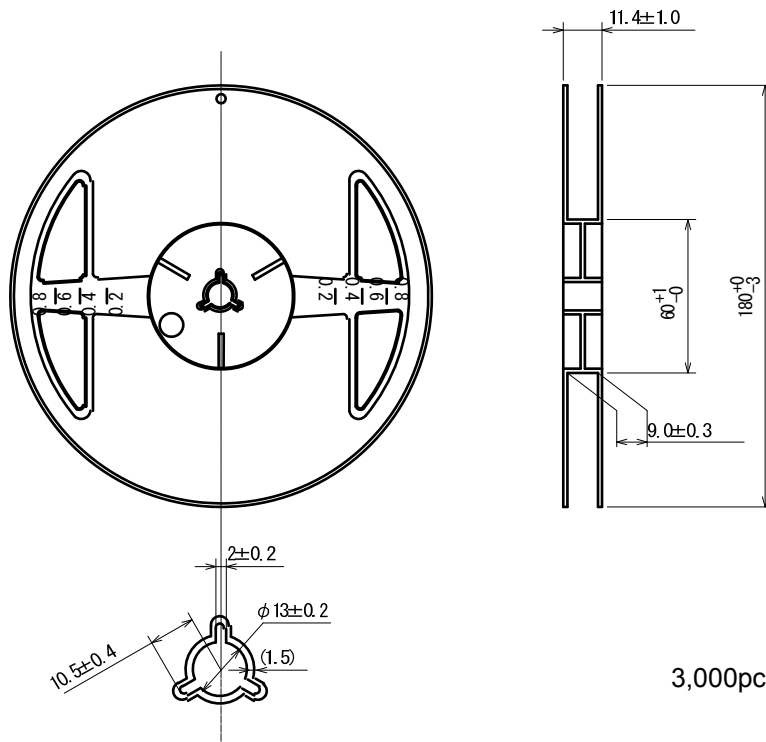

3,000pcs/reel

●テーピング仕様/Taping Specifications

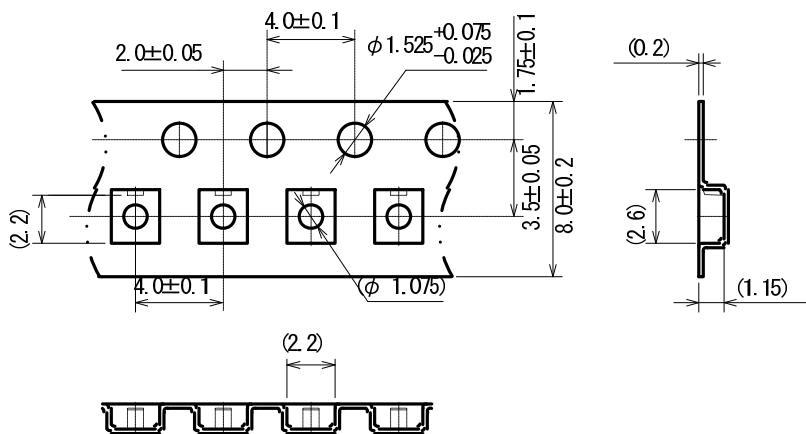

direction of feed

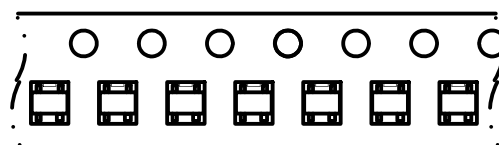

R Type : [Device orientation : Right]

Standard feed

● **SSOT-24 Power Dissipation**

Power dissipation data for the SSOT-24 is shown in this page.

The value of power dissipation varies with the mount board conditions.

Please use this data as one of reference data taken in the described condition.

1. Measurement Condition (Reference data)

Condition: Mount on a board

Ambient: Natural convection

Soldering: Lead (Pb) free

Board: Dimensions 40 x 40 mm (1600 mm<sup>2</sup> in one side)

Copper (Cu) traces occupy 50% of the board area

In top and back faces

Package heat-sink is tied to the copper traces

Material: Glass Epoxy (FR-4)

Thickness: 1.6 mm

Through-hole: 4 x 0.8 Diameter

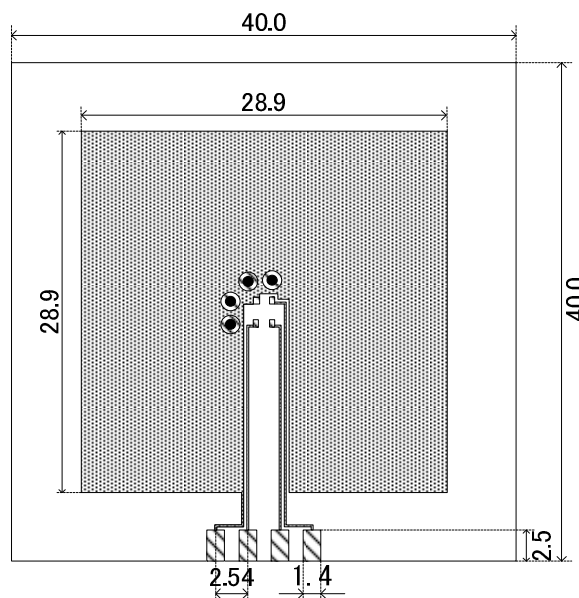

Evaluation Board (Unit: mm)

2. Power Dissipation vs. Ambient temperature

Board Mount ( $T_j \text{ max} = 125^\circ\text{C}$ )

Ambient Temperature ( $^\circ\text{C}$ )	Power Dissipation $P_d$ (mW)	Thermal Resistance ( $^\circ\text{C}/\text{W}$ )
25	500	200.00
85	200	

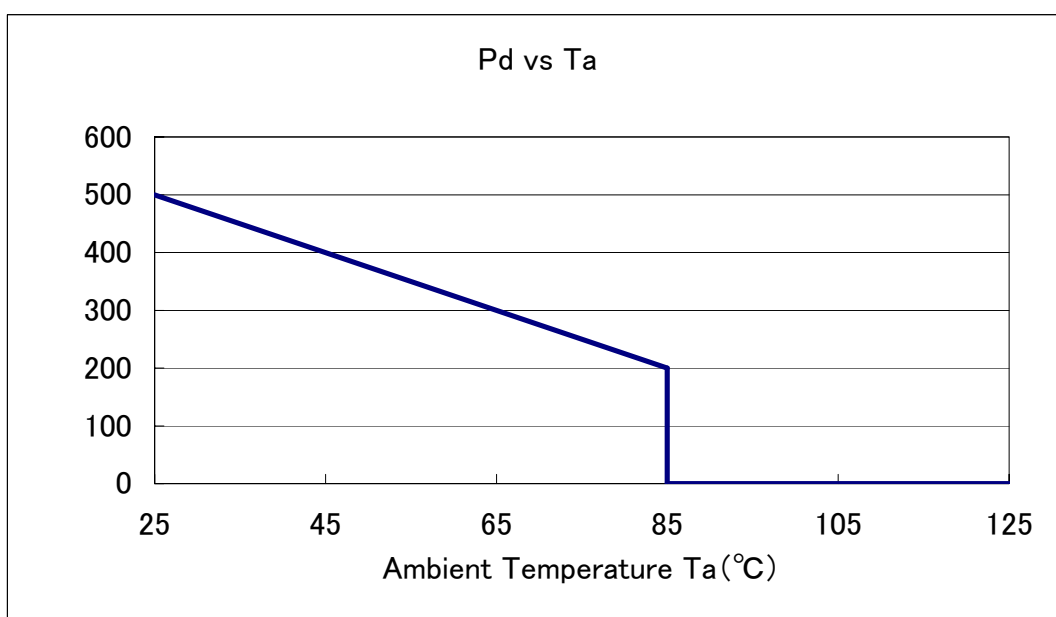

# SSOT-24 構造図 SSOT-24 Perspective

RoHS対応品  
RoHS Compliance

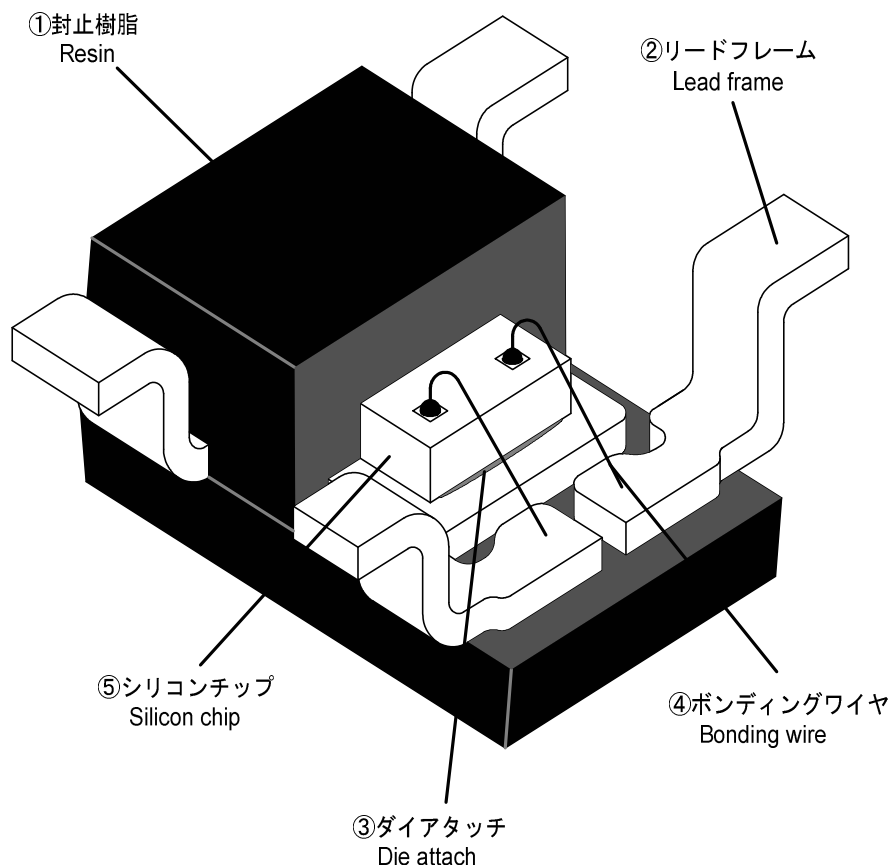

項目 Item	材料 Material	備考 Note
① 封止樹脂 Resin	エポキシ樹脂 Epoxy resin	難燃グレード/Flammability rating UL94V-0
② リードフレーム Lead frame	銅系 Copper alloy	
端子処理 Lead plating	鉛フリーはんだメッキ Lead(Pb) free solder plating	
③ ダイアタッチ Die attach	エポキシ Epoxy	
④ ボンディングワイヤ Bonding wire	Au	
⑤ シリコンチップ Silicon chip	Si	

捺印表示 Marking	レーザー Laser marking
-----------------	-----------------------